



Hi Rancher

Livestock Scale

Load Bars

ABH

User Manual

A professional weighing products manufacturer and supplier

An ISO9001 registered company

Room 812, Building 3, Tiandu Tower, No. 211 Changjiang Road, Suzhou City, Jiangsu Province, China

www.hiweigh.com | info@hiweigh.com

INDEX

Section 1	1
Unpacking the box	
Section 2	1
Weighing system	
Section 3	2
Getting around	
Section 4	3
Testing	
Section 5	4
Troubleshooting	

Section 1 ● ● ●

Unpacking the box



For most applications you will need two ABH series load bars. Note: you may also need adaptor plates for your chute.

Section 2 ● ● ●

Weighing system

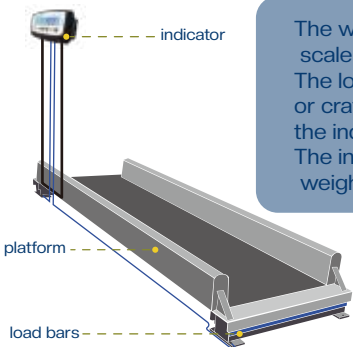

The weighing system consists of a weight scale indicator and two load bars. The load bar is installed under the platform or crate and transmits the weight signal to the indicator. The indicator will display and record the weight.

The upper part of the load bar has two 13 mm diameter fixing holes, and the foot plate has four 12.5 mm diameter fixing holes, which can be installed under a platform or a crate.

Note: Our company's AAC/AAG can be matched matched

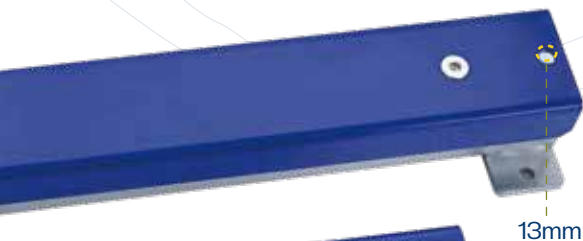

Testing

Once installed, you should test with a weigh scale indicator.

- Connect the load bar cables to a indicator. (like K7)
Turn on and zero the indicator.
- Put a test weight (which may be yourself or another person) at one end of the platform/crate and note the stable reading on the indicator.
- Put the test weight at the other end of the platform/crate and note the stable reading on the indicator.
- Remove the test weight and note whether the reading returns to zero.
- If the two readings differ by more 2% of capacity or the reading does not return to zero, see the troubleshooting section.

Note: During use, if the device has not been used for a period of time, repeat the above test before using it for the first time.

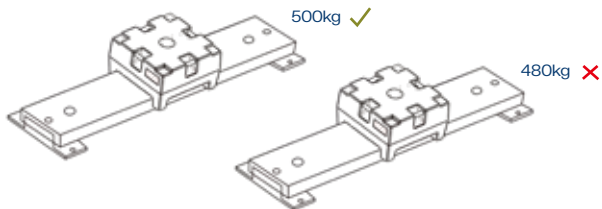

Fault	Remedy
<p>Reading does not return to zero between animals/Difference in readings at each end of the platform/Under reading(reading lighters than expected)</p>	<ol style="list-style-type: none"> 1.Ensure that the platform/crate is not touching objects that may alter the weights. Typical causes are binding against fixed metalwork or built up of dirt. 2.Check that the load bar feet are sitting evenly on the ground. 3.Check that bolt hole are not misaligned,as this may put a residual load on the load bars. 4.Recalibrate the load bars
<p>Reading is unstable</p>	<ol style="list-style-type: none"> 1.Moisture in the load bar connector. Remove moisture form the plugs and caps using methylated spirits.ethyl alcohol,or a suitable electricl contact cleaner. 2.Damaged cable. 3.Moisture in the load cell. 4.Moisture in the junction box.
<p>Reading moves,display shows underload or overload.</p>	<ol style="list-style-type: none"> 1.Damaged cable. 2.Damaged indicator.

Further information

- Do not leave the indicator ,load bars or plugs immersed in waters.
- Cables should be placed so that they will not be damaged.





An ISO9001 registered company

Room 812, Building 3, Tiandu Tower, No. 211 Changjiang Road, Suzhou City, Jiangsu Province, China

www.hiveigh.com